

2250 Watt X-Band Rack Mount High Power Amplifier



FEATURES

- Compact Size
- High Efficiency
- Digital Display and Control Interface
- Power Factor Correction
- Linearizer Option

XTRD-2000X digital rack-mount amplifier is designed for fixed and mobile uplink application. The high efficiency traveling wave tube amplifier includes RF gain control, a solid state pre-amplifier, RF filter, cooling, and a monitor & control (M&C) system. An integrated X-Band linearizer is available. The dual-drawer amplifier conserves rack space and occupies only 19.25 inches (11 rack units) of a standard 19 inch rack cabinet. A complete 1:1 or 1:2 redundant TWTA system, including a redundant controller, can be mounted in a single rack.

The **XTRD-2000X** features a menu-driven front panel display and RS-232 & RS-422/RS-485 serial port interfaces for complete remote control. Gain control is set by the front panel manual control or by computer commands sent via the remote interface(s).

The unit incorporates a high efficiency, multi-stage depressed collector TWT. Reliability is enhanced because both prime power consumption and internal operating temperatures are reduced for the linear and saturated modes of operation. The high frequency resonant conversion power supply is highly efficient and allows for quick recovery from prime power outages. Depending upon user requirements, the **XTRD-2000X** can be configured for single-thread, redundant, or phase combined operation.



[BUY NOW](#)

PERFORMANCE SPECIFICATION

Parameters	XTRD-2000X
FREQUENCY RANGE	7.90 to 8.40 GHz
OUTPUT POWER	
Traveling Wave Tube	2250 W
Rated Power @ Amplifier Flange (minimum)	2000 W
GAIN	
Large Signal (minimum)	70 dB
Small Signal (minimum)	75 dB
Attenuator Range (continuous)	25 dB
Maximum SSG Variation Over:	
Any Narrow Band	1.0 dB per 40 MHz
Full Band	2.5 dB
Slope (maximum)	± 0.04 dB/MHz
Stability, 24 hr. (maximum)	± 0.25 dB
Stability, Temperature (maximum)	± 1.0 dB over temperature range at any frequency
INTERMODULATION (maximum) with two equal carriers	-17 dBc @ 4 dB total output power backoff from rated power
HARMONIC OUTPUT (maximum)	-60 dBc
AM/PM CONVERSION (maximum)	2.5 deg/dB at 6 dB below rated power
NOISE POWER (maximum)	
Transmit Band	-70 dBW/4 kHz
Receive Band	-70 dBW/4 kHz 7.25 to 7.75 GHz
GROUP DELAY (maximum)	
Bandwidth	Any 40 MHz
Linear	± 0.01 nS/MHz
Parabolic	± 0.005 nS/MHz ²
Ripple	0.5 nS/Pk-Pk
RESIDUAL AM NOISE (maximum)	-50 dBc to 10 kHz -20 (1.5 + logf) dBc 10 to 500 kHz -85 dBc above 500 kHz
PHASE NOISE (maximum)	10 dB below IESS phase noise profile AC fundamental -50 dBc Sum of all spurs -47 dBc
VSWR	
Input (maximum)	1.3:1
Output (maximum)	1.3:1

BLOCK DIAGRAM

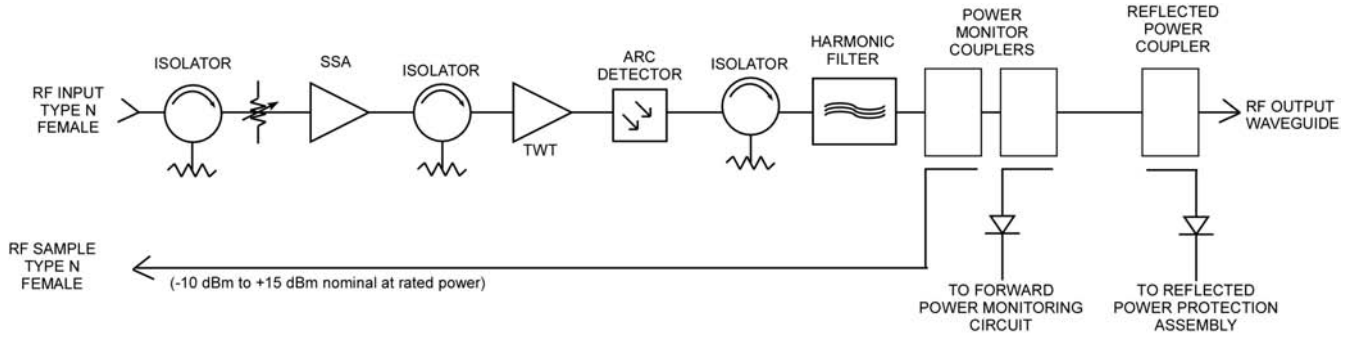

OUTLINE DRAWING

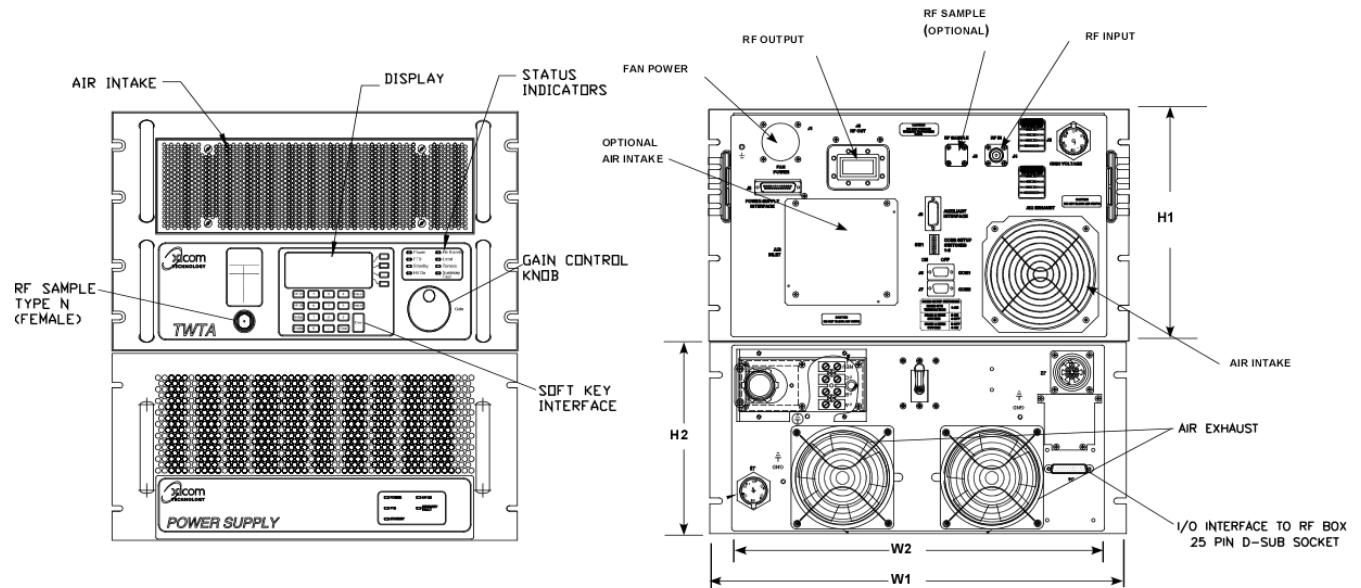

DIMENSIONS				
	INCHES	CENTIMETERS	INCHES	CENTIMETERS
W1	19.00	48.27	H1	10.09 25.63
W2	17.00	43.18	H2	8.72 22.15
RF OUTPUT: CPRG-112			NOMINAL WEIGHT = 230 lb (104.33 kg)	

PRIME POWER

208 VAC ± 10% Three Phase, 4 Wire, 47 to 63 Hz
 7500 VA
 0.95 Minimum Prime Power Factor



ENVIRONMENT

NONOPERATING TEMPERATURE RANGE	-50°C to +70°C
OPERATING TEMPERATURE RANGE	-10°C to +50°C (2°C/1000 Feet Derating)
HUMIDITY	Up to 95% Noncondensing
ALTITUDE	10,000 Feet MSL (maximum)
SHOCK AND VIBRATION	Normal Transportation
COOLING	Forced Air 275 CFM (typical)

INTERFACE

	Type	Function	
CONTROLS	LOCAL	Local/Remote	AC Power On/OFF
	LOCAL AND REMOTE	Gain	High Voltage ON/OFF
		Min/Max Power Alarm/Fault	Audio Alarm ON/OFF
		Reflected Power Alarm/Fault	Units (Watts, dBm, dBW)
		Fault Reset	Lamp Test
		Heater Standby ON/OFF	Frequency Select
STATUS	FRONT PANEL LEDs	Standby	Power
		Local	Remote
		Summary Fault	High Voltage ON/OFF
		Heater Time Out (FTD)	Heater Standby
	FRONT PANEL DIGITAL DISPLAY	Power Out	Beam Hours
		Reflected Power	Helix Current
		TWT Temperature	Helix Voltage
		Units Selection	Attenuator Setting
		Heater Hours	Faults: High VSWR High Voltage Helix Current TWT Temperature
	DRY FORM-C RELAY CONTACTS (2)	Summary Fault	
COMPUTER SERIAL PORT	HARDWARE INTERFACE	Two Ports: RS-232 & RS-422/RS-485	
	XICOM COMMAND SET	ASCII Commands	
	RF SAMPLE PORT COUPLING	-47 dB Nominal	

OPTIONS

- 220/380 VAC ± 10% Three Phase, 5 Wire, 47 to 63 Hz
- 240/415 VAC ± 10% Three Phase, 5 Wire, 47 to 63 Hz
- 1:1, 1:2, 1:N Redundancy
- Variable Phase Combined
- Integrated Linearizers



Post Office Box 1639
 101 Eagle Road - Building #7
 Avon, Colorado 81620 USA
 970 748-3094 or tollfree 866 SATCOM1
 Fax 970 748-3096
www.satcomresources.com



Document XTRD-2000X Rev 6, 01/04/2011
 © 2011

Note: Technical specifications are subject to change without notice. Please contact Xicom Technology before using this information for system design.